

# Secondary Glazing

## Section Identification Guide



DURATION  
WINDOWS



# Contents

|                            |    |
|----------------------------|----|
| Systems                    | 3  |
| Horizontal sliders         | 4  |
| Economy Sections           | 5  |
| Luxury Subframe Sections   | 6  |
| Slim Line Equal Leg        | 7  |
| Vertical Sliders           | 8  |
| Tilt-Back                  | 9  |
| Balanced                   | 10 |
| Non-Balanced               | 11 |
| Heavy Duty & Sections      | 12 |
| Friction Hinged & Sections | 13 |
| Butt Hinged & Sections     | 14 |
| Medium Duty Hinged         | 15 |
| Combination Units          | 15 |
| Lift Outs & Sections       | 16 |
| Fixed                      | 17 |
| Fly Screens                | 18 |
| Trickle Vents & Trims      | 19 |

## System Specification

|            |  |
|------------|--|
| SECTIONS   | Outer frames and insert panels are made from warp free rigid sections of extruded aluminium alloy 6063 T6 B.S. 1474 (HE9TE).   |
| FINISH     | Our standard finish is white semi-gloss polyester powder coated aluminium to B.S. 6496.<br>Silver Anodised, Brown and RAL colours are available at extra cost.<br>Most wooden sub-frames are pre-primed in white.<br>Brown units are supplied with hardwood unpainted sub-frames and trims.              |
| WEATHERING | Moisture repellent, rot free silicone treated polypropylene pile strip is fitted to all insert panels.   |
| GLAZING    | 4mm or 6mm float glass is used in accordance with B.S.CP 152 and 4mm, 6mm toughened, 6.4mm laminated are used in accordance with B.S.6262. All glazing is carried out at the factory prior to despatch, each panel being bedded in Glazepta synthetic rubber gaskets thus providing a cushioning effect. |

We reserve the right to make changes to the product specification as technical developments dictate, and without prior notice.  
Pictures shown are for illustrative purposes and are not binding in detail, colour or specification.

# Secondary Systems

Our secondary glazing is available in four main systems; Economy Odd Leg, Slim-Line Equal Leg, Subframe and Heavy Duty. Each system is available in a range of different styles as listed below.

## Economy Odd Leg

Our Economy Odd Leg system is a very cost effective aluminium secondary glazing system. It is easy to fit, with pre-drilled fixing holes. Simply face fix your secondary glazing onto the existing windows.

Available Styles:

- Fixed
- Two Track Horizontal Slider
- Balanced Vertical Slider (No tilt facility)
- Non-Balanced Vertical Slider (No tilt facility)
- Butt & Friction Hinged
- Lift Out



Face Fix

## Luxury Subframe

Our Luxury Subframe system has an additional wooden frame that wraps around the aluminium frame. The subframes come in a choice of wood types and depths for face fixing or reveal fixing. Trims are available to give a neat clean finish.

Available Styles:

- Two & Three Track Horizontal Sliders
- Tilt Back Balanced Vertical Slider
- Balanced Vertical Slider (No tilt facility)
- Non-Balanced Vertical Slider (No tilt facility)
- Butt & Friction Hinged
- Lift Out

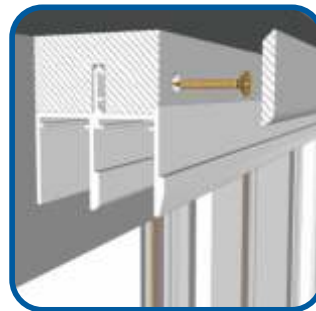

Face Fix



Reveal Fix

## Slim-Line Equal Leg

Our Slim-Line secondary offers the slimmest sight-lines out of our four systems. The system is all aluminium and can be face or reveal fixed.

Available Styles:

- Two Track Horizontal Slider
- Tilt Back Balanced Vertical Slider
- Balanced Vertical Slider (No tilt facility)
- Non-Balanced Vertical Slider (No tilt facility)
- Lift Out



Face Fix



Reveal Fix

## Heavy Duty

Our Heavy Duty system is stronger and more robust than our other secondary glazing systems. The thicker frames enable it to take double glazed sealed units and achieve larger maximum sizes.

Available Styles:

- Two Track Horizontal Slider
- Balanced Vertical Slider (No tilt facility)



Reveal Fix

# Horizontal Sliders

## Designs and Sizes

Horizontal Sliding secondary windows are available in 2,3,4 or 5 panel configurations, sliding on a track system with nylon skids and fitted with spring loaded aluminium catches engaging on the inside of the outer frame jambs for improved security. All sliding panels interlock at meeting styles thus providing a draught proof seal.

### Two Track Designs

Two Panels - Both Slide

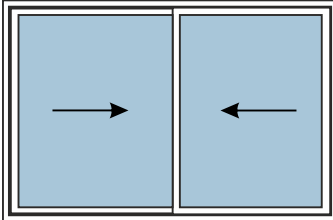

Three Panels - All Sliding

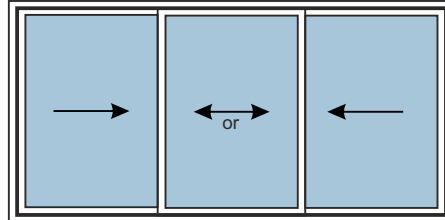

Three Panels: Centre Fixed

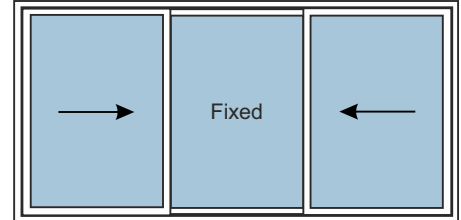

Four Panels: All Sliding

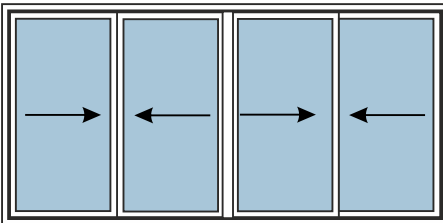

Five Panels: Centre Fixed - Four Panels Slide\*

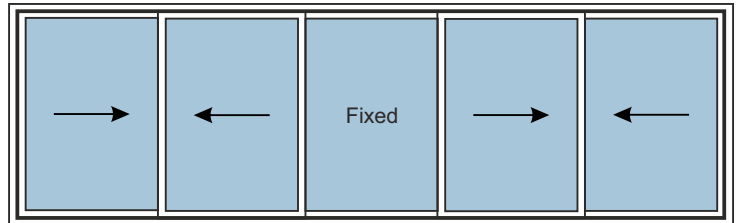

\* Configuration only applies to Economy, Slim-Line and Luxury Subframe

### Three Track Designs

Three Panels - All Sliding

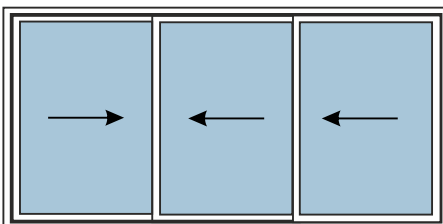

This three track, three panel horizontal slider gives maximum ventilation and access to the prime windows.

### Recommended Sizes

These measurements are representative of our Economy, Slim-Line and Luxury Subframe Systems.

| 2 Panel    |         |
|------------|---------|
| Min Width  | 400 mm  |
| Max Width  | 2500 mm |
| Min Height | 400 mm  |
| Max Height | 1980 mm |

| 3 Panel    |         |
|------------|---------|
| Min Width  | 600 mm  |
| Max Width  | 3750 mm |
| Min Height | 400 mm  |
| Max Height | 1980 mm |

| 4 Panel    |         |
|------------|---------|
| Min Width  | 800 mm  |
| Max Width  | 4900 mm |
| Min Height | 400 mm  |
| Max Height | 1980 mm |

| 5 Panel    |         |
|------------|---------|
| Min Width  | 1000 mm |
| Max Width  | 4900 mm |
| Min Height | 400 mm  |
| Max Height | 1980 mm |

Please note: All these sizes are recommended sizes and special requests to go under or over these sizes may be possible but will not carry the standard guarantee.

# Economy Horizontal Slider

## Sections

Two Panels - Both Slide

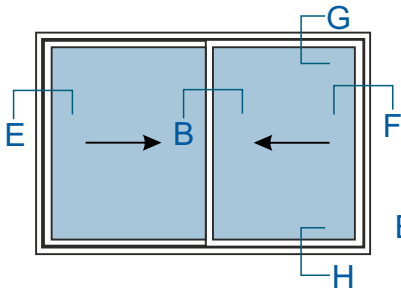

Three Panels - All Sliding

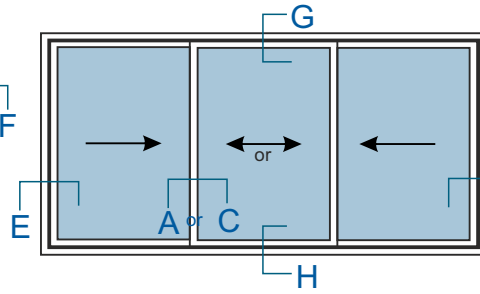

Three Panels: Centre Fixed

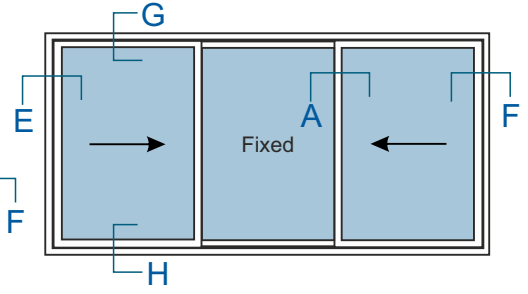

Four Panels: All Sliding

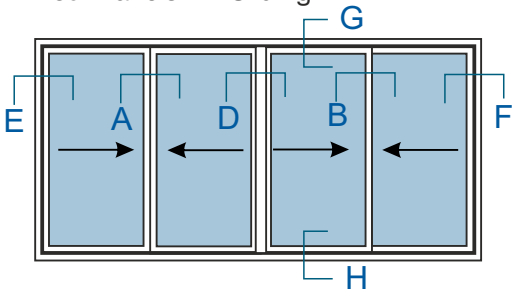

Five Panels: Centre Fixed - Four Panels Slide

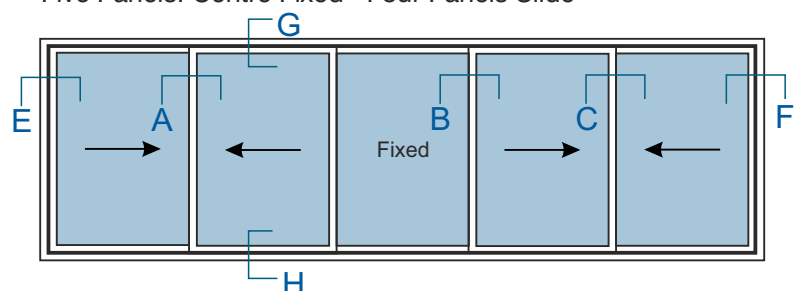

## Two Track Only

Section A

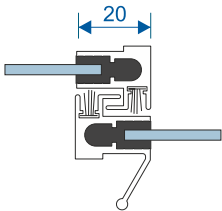

Section B

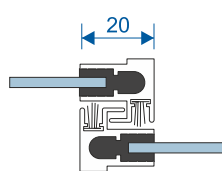

Section C

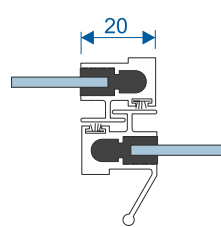

Section D

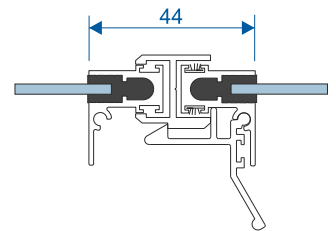

Section E

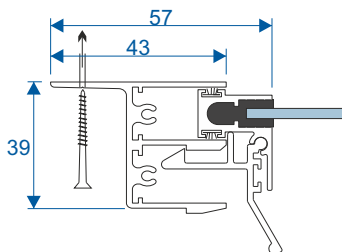

Section F

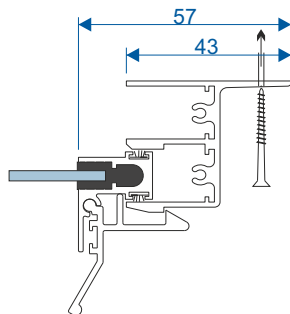

Section G

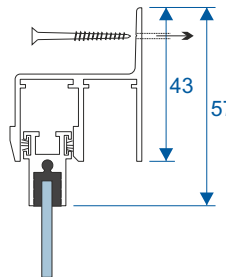

Section H

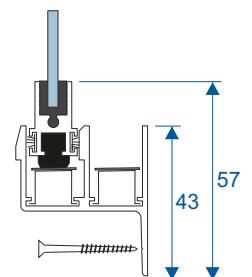

For more in-depth technical please contact us or consult our website.

# Subframe Horizontal Slider

## Sections

Two Panels - Both Slide

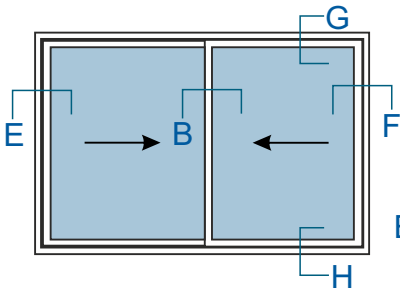

Three Panels - All Sliding

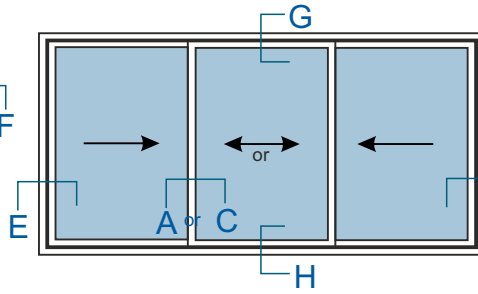

Three Panels: Centre Fixed

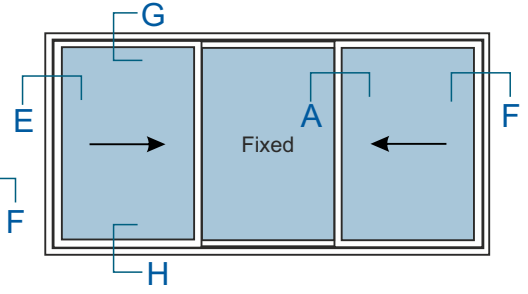

Four Panels: All Sliding

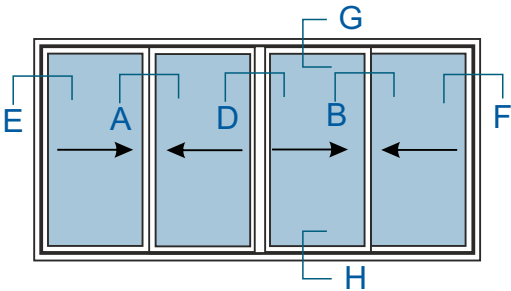

Five Panels: Centre Fixed - Four Panels Slide

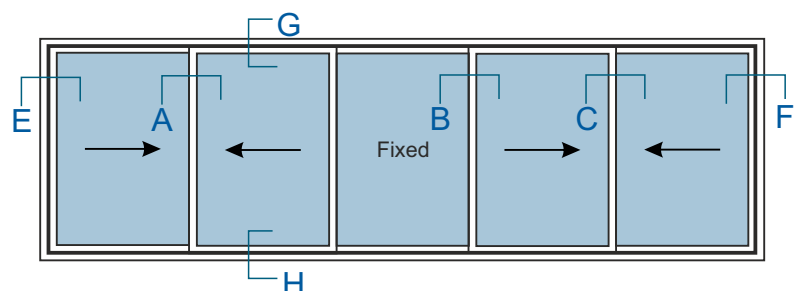

Section A

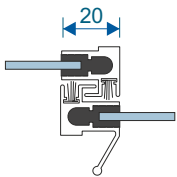

Section B

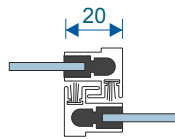

Section C

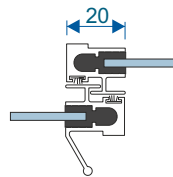

Section D

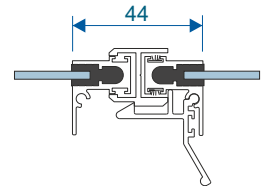

Note drawings below show both face fix and reveal fix. Reveal fix shown by the hatched area.

## Two Track

Section E

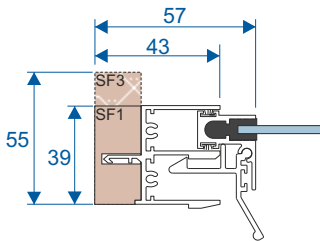

Section F

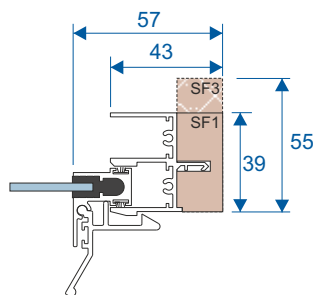

Section G

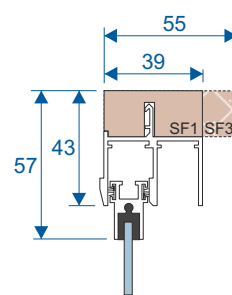

Section H

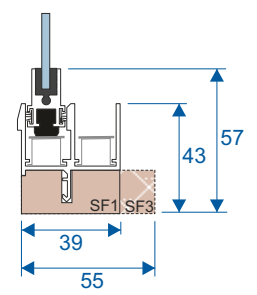

## Three Track

Section E

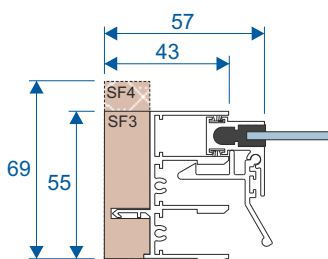

Section F

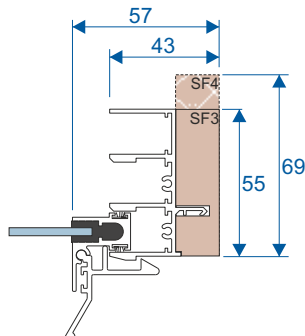

Section G

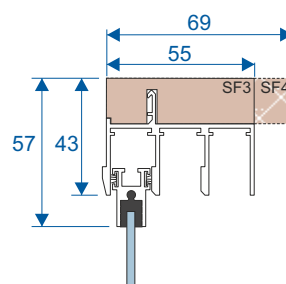

Section H

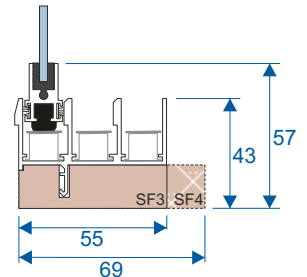

For more in-depth technical please contact us or consult our website.

# Slim-Line Horizontal Slider

## Sections

Two Panels - Both Slide

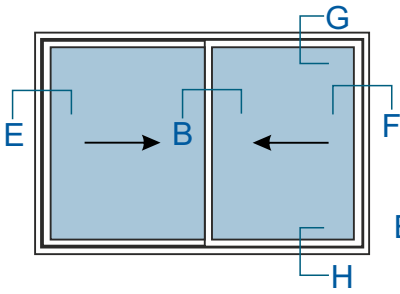

Three Panels - All Sliding

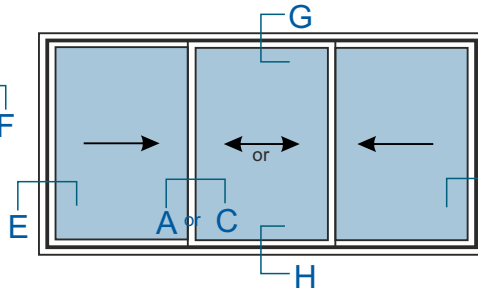

Three Panels: Centre Fixed

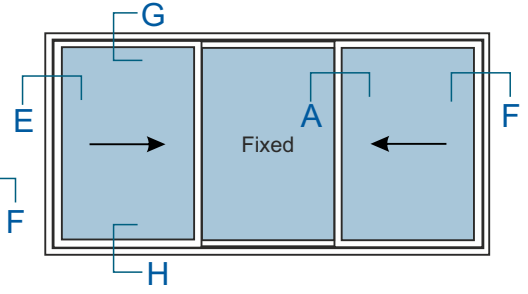

Four Panels: All Sliding

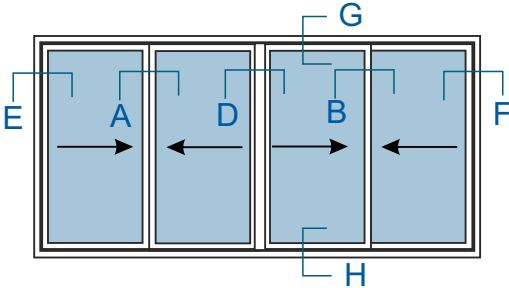

Five Panels: Centre Fixed - Four Panels Slide

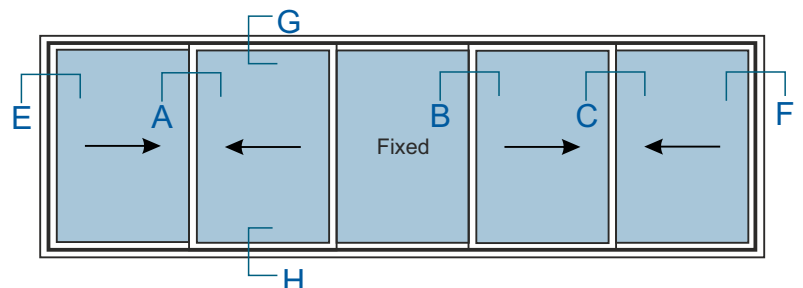

Section A

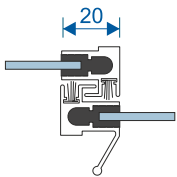

Section B

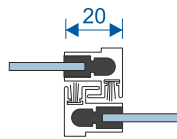

Section C

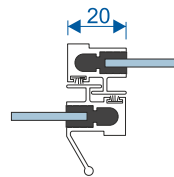

Section D

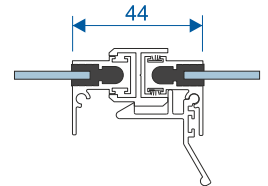

## Face Fixed

Section E

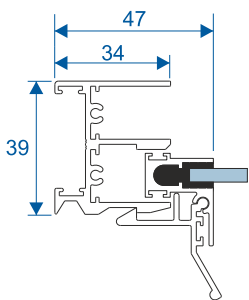

Section F

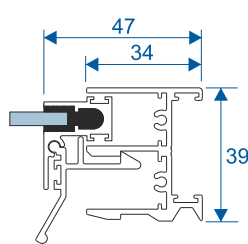

Section G

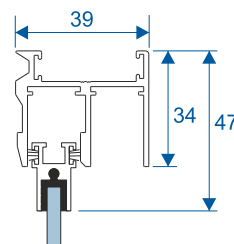

Section H

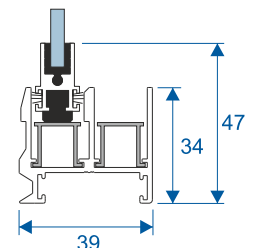

## Reveal Fixed

Section E

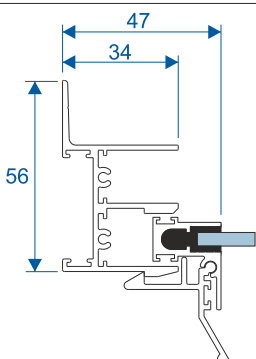

Section F

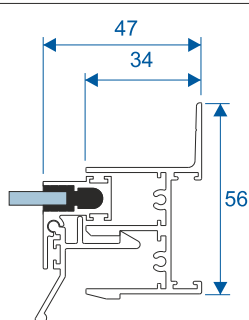

Section G

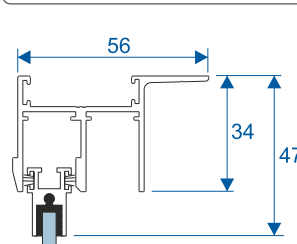

Section H

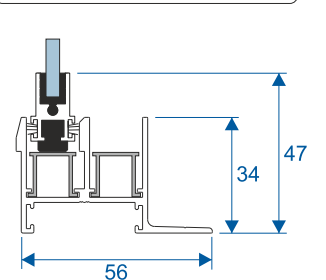

For more in-depth technical please contact us or consult our website.

# Vertical Sliders

## Designs and Sizes

Vertical Sliding secondary glazing is ideal for heat and sound proofing traditional wooden box sash windows, or any windows that have horizontal bars. Panels slide open in the same way as vertical sliding sash windows and provide easy access to the existing window.

### Balanced Tilt Back - Subframe or Slim-Line

Balanced Tilt Back Vertical Sliders are hung on spiral balances concealed in the jambs, and adjusted to suit the weight of the panels. Panels are held closed with a Fitch Fastener positioned in the centre of the transom bar. The head of each panel has a spring loaded catch in the corner, enabling each panel to tilt back individually for ease of cleaning and access to prime window for decorating.

#### Recommended Sizes

|            |         |
|------------|---------|
| Min Width  | 400 mm  |
| Max Width  | 1250 mm |
| Min Height | 800 mm  |
| Max Height | 2450 mm |

Please note

- Balanced Tilt Back is not available in Odd Leg Systems
- Maximum panel weights are 18kg
- 4mm Glass 10.2kg m<sup>2</sup>
- 6mm Glass 15.2kg m<sup>2</sup>
- All these sizes are recommended sizes and special requests to go under or over these sizes may be possible but will not carry the standard guarantee.

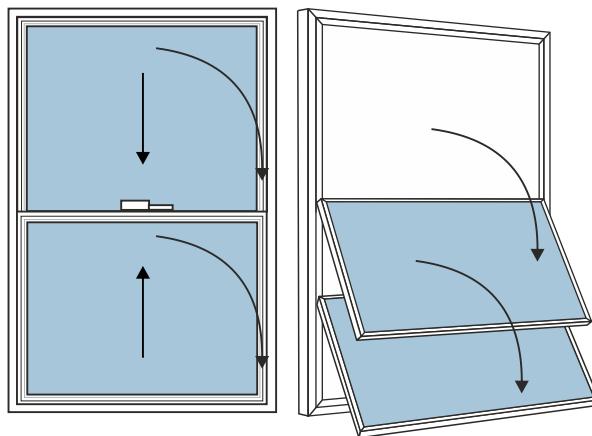

### Balanced - Economy, Slim-Line or Subframe

Balanced Vertical Sliders are hung on spiral spring balances concealed in the jambs and adjusted to suit the weight of the panels. Both panels are held closed with a Fitch Catch fastener positioned in the centre of the transom bar. The panels cannot be removed or tilted in for cleaning.

#### Recommended Sizes

|            |         |
|------------|---------|
| Min Width  | 400 mm  |
| Max Width  | 1250 mm |
| Min Height | 800 mm  |
| Max Height | 2450 mm |

Please note

- Maximum panel weights are 18kg
- 4mm Glass 10.2kg m<sup>2</sup>
- 6mm Glass 15.2kg m<sup>2</sup>
- All these sizes are recommended sizes and special requests to go under or over these sizes may be possible but will not carry the standard guarantee.

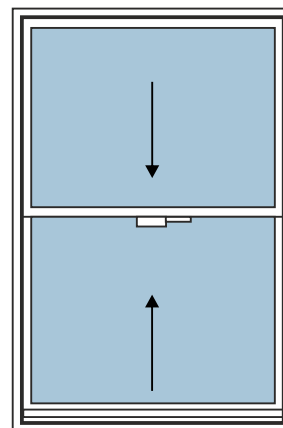
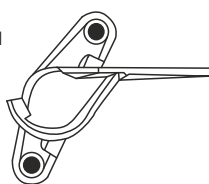

### Non-Balanced - Economy, Slim-Line or Subframe

THE OPERATOR MUST SUPPORT THE WEIGHT OF THE PANEL WHEN SLIDING. The panels are held with spring loaded nylon bolts which locate in pre-set stop positions in the jamb to hold the panel in the desired open position. Panels can be removed for easy cleaning.

#### Recommended Sizes

|            |         |
|------------|---------|
| Min Width  | 400 mm  |
| Max Width  | 1250 mm |
| Min Height | 600 mm  |
| Max Height | 1850 mm |

Please note

- Maximum panel weights are 18kg
- 4mm Glass 10.2kg m<sup>2</sup>
- 6mm Glass 15.2kg m<sup>2</sup>
- All these sizes are recommended sizes and special requests to go under or over these sizes may be possible but will not carry the standard guarantee.

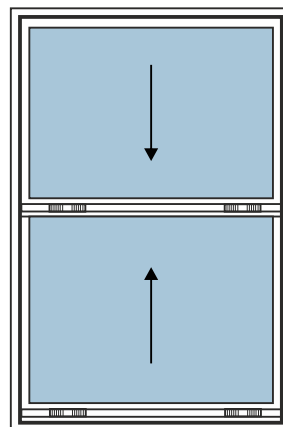
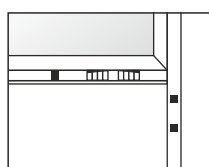



# Tilt- Back Vertical Slider

## Sections

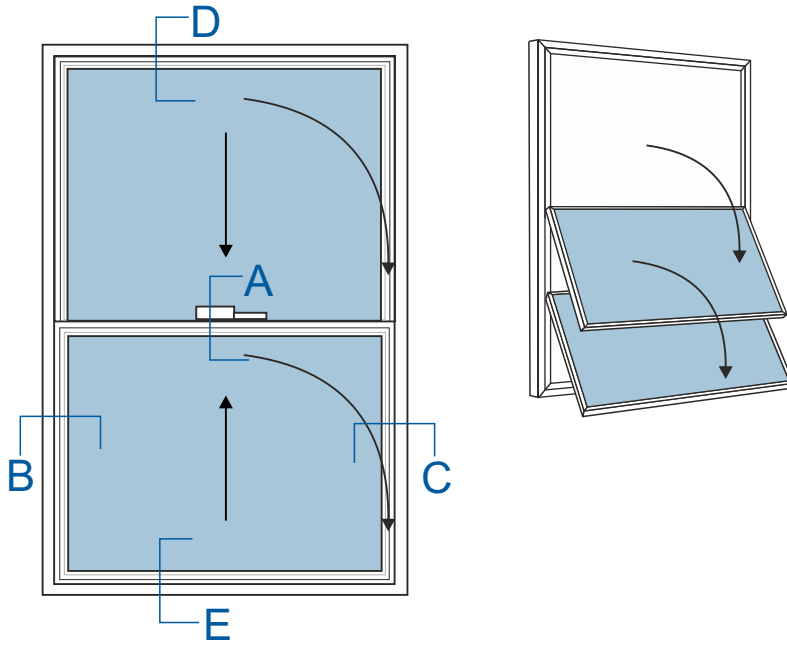

### Section A

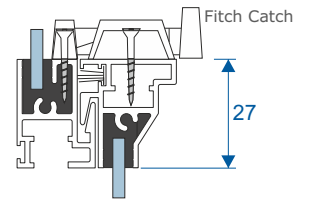

Note subframe drawings below show both face fix and reveal fix. Reveal fix shown by the hatched area.

## Subframe

### Section B

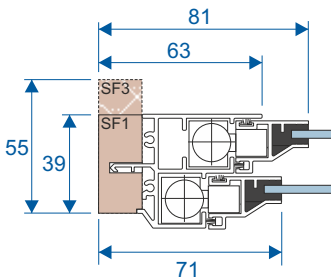

### Section C

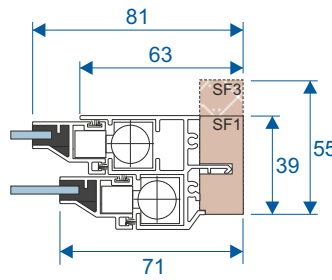

### Section D

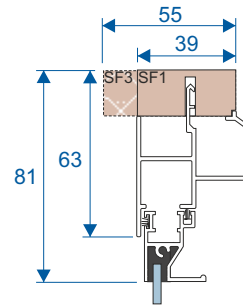

### Section E

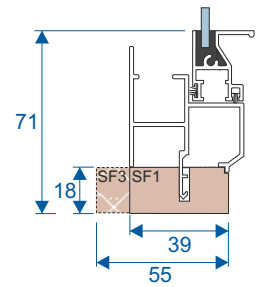

## Slim-Line

### Section B

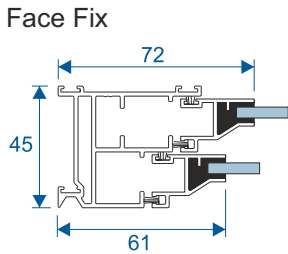

### Section C

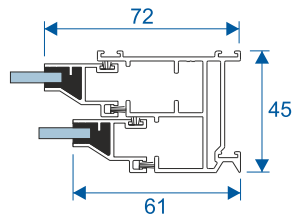

### Section D

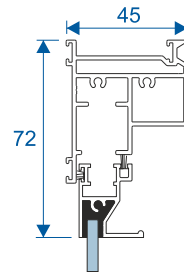

### Section E

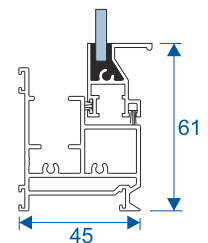

### Reveal Fix

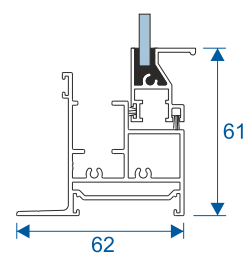
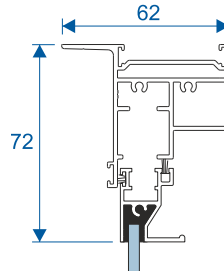
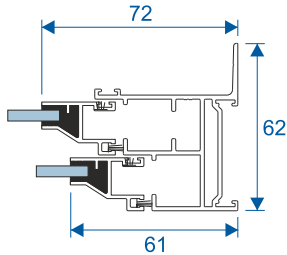
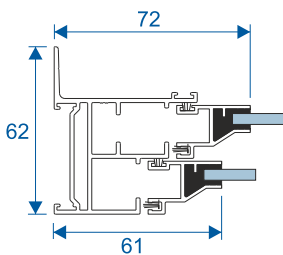

For more in-depth technical please contact us or consult our website.

# Balanced Vertical Slider

## Sections

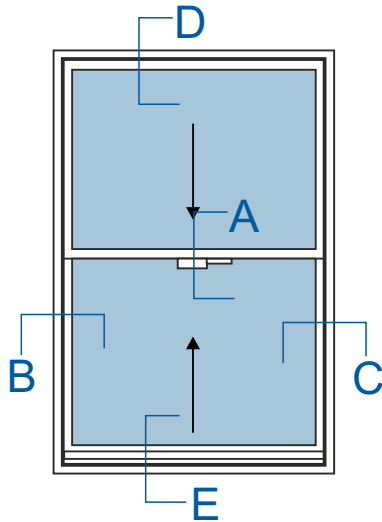

Section A

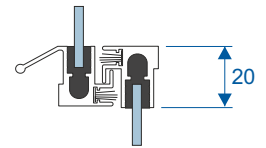

## Economy

Section B

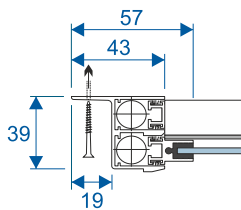

Section C

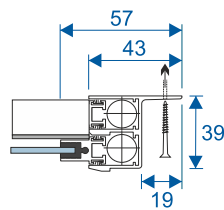

Section D

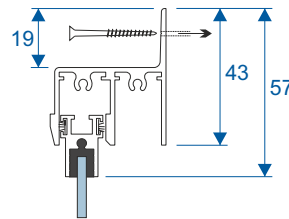

Section E

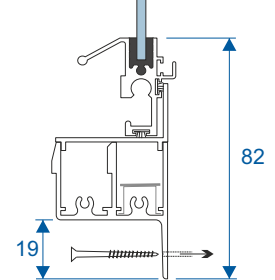

Note drawings below show both face fix and reveal fix. Reveal fix shown by the hatched area.

## Subframe

Section B

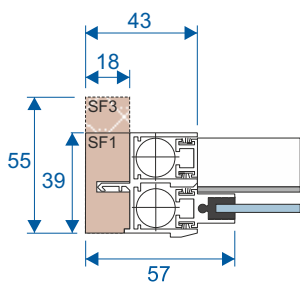

Section C

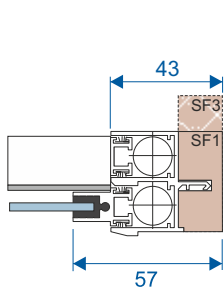

Section D

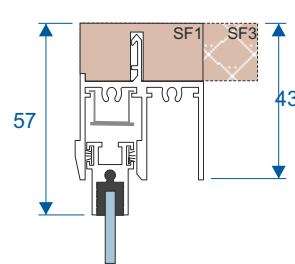

Section E

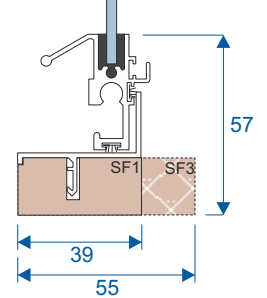

## Slim-Line

Section B

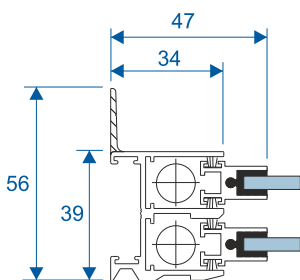

Section C

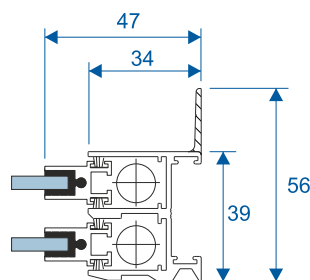

Section D

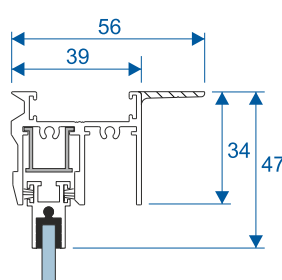

Section E

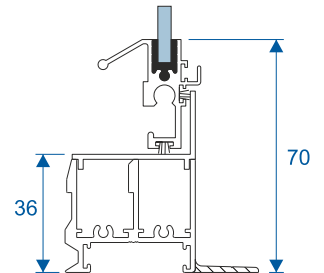

For more in-depth technical please contact us or consult our website.

# Heavy Duty

## Designs, Sizes & Sections

Heavy Duty secondary glazing has a more robust frame and also has the option of either single glazed or double glazed sealed units. Our heavy duty system is available as horizontal or vertical sliding and is reveal fix only.

### Recommended Sizes - Horizontal Sliding

| 2 Panel    |         |
|------------|---------|
| Min Width  | 800 mm  |
| Max Width  | 3000 mm |
| Min Height | 400 mm  |
| Max Height | 2400 mm |

| 3 Panel    |         |
|------------|---------|
| Min Width  | 1200 mm |
| Max Width  | 4500 mm |
| Min Height | 400 mm  |
| Max Height | 2400 mm |

| 4 Panel    |         |
|------------|---------|
| Min Width  | 1600 mm |
| Max Width  | 4900 mm |
| Min Height | 400 mm  |
| Max Height | 2400 mm |

### Recommended Sizes - Vertical Sliding

| Sizes      |         |
|------------|---------|
| Min Width  | 400 mm  |
| Max Width  | 1500 mm |
| Min Height | 900 mm  |
| Max Height | 2800 mm |

Please note:

- Maximum panel weights are 50kg
- 4mm Glass - Single Glazed: 10.2kg m<sup>2</sup> / Double Glazed: 20.4kg m<sup>2</sup>
- 6mm Glass - Single Glazed: 15.2kg m<sup>2</sup> / Double Glazed: 30.4kg m<sup>2</sup>
- All these sizes are recommended sizes and special requests to go under or over these sizes may be possible but will not carry the standard guarantee.
- Panels are not able to be lifted out for cleaning.

### Two Panel Horizontal Slider

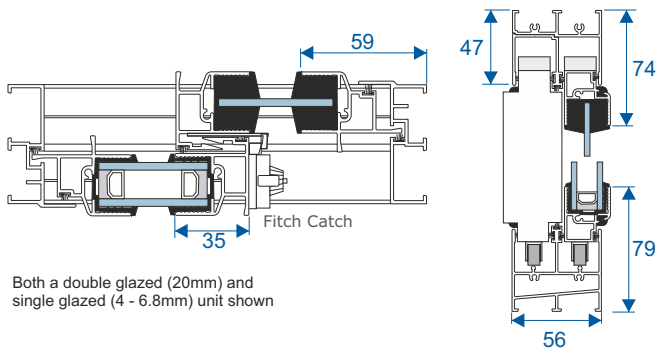

Both a double glazed (20mm) and single glazed (4 - 6.8mm) unit shown

### Vertical Sliding Heavy Duty Secondary

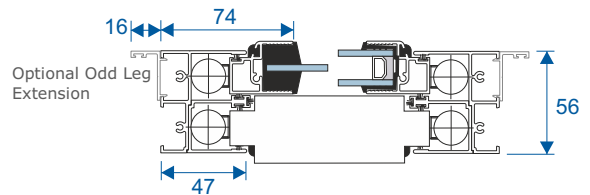

### Three Panel All Sliding Horizontal Slider

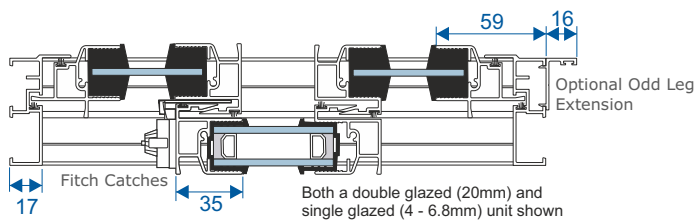

Both a double glazed (20mm) and single glazed (4 - 6.8mm) unit shown

### Four Panel All Sliding Horizontal Slider

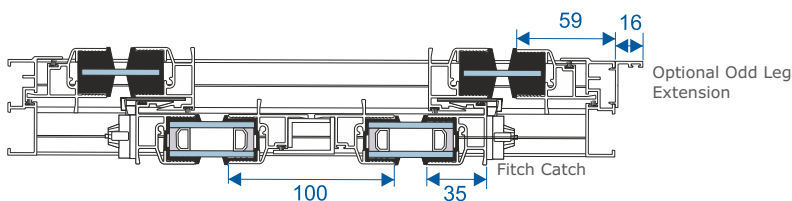

Both a double glazed (20mm) and single glazed (4 - 6.8mm) unit shown

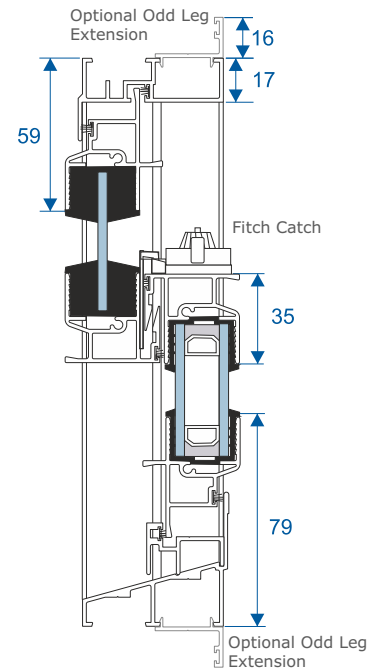

Both a double glazed (20mm) and single glazed (4 - 6.8mm) unit shown.

#### 16mm odd leg extension:

Both of our heavy duty systems as shown on this page can be fitted with an odd leg extension. This can be added to any part of the frame to make the frame longer on one side. Equally it can be placed on both sides (inside & out) of the frame to extend it for any reason you may need it on site.

For more in-depth technical please contact us or consult our website.

# Non-Balanced Vertical Slider

## Sections

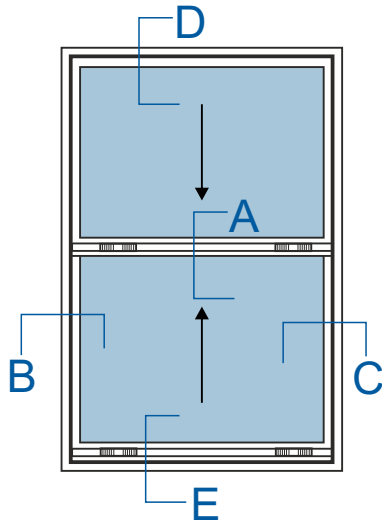

### Economy

**Section A**

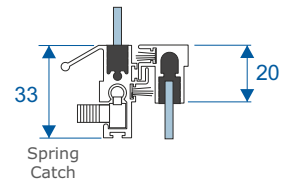

**Section B**

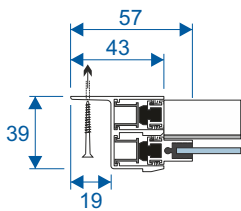

**Section C**

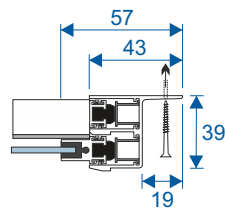

**Section D**

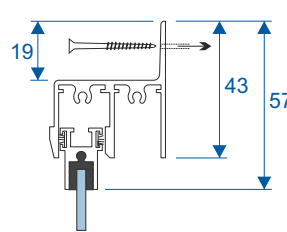

**Section E**

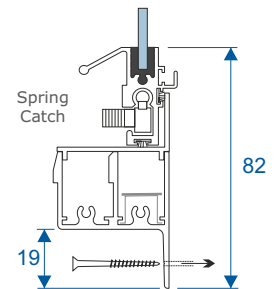

Note drawings below show both face fix and reveal fix. Reveal fix shown by the hatched area.

### Subframe

**Section B**

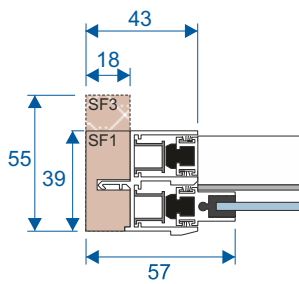

**Section C**

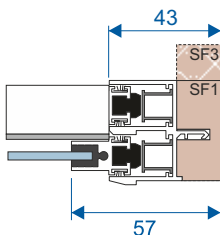

**Section D**

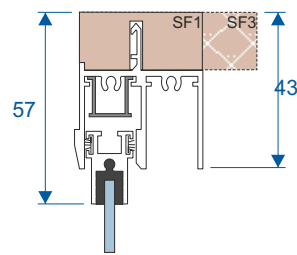

**Section E**

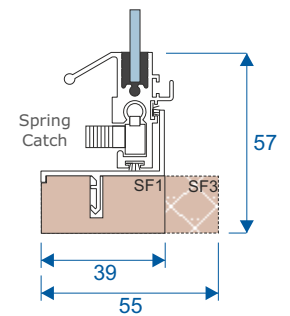

### Slim-Line

**Section B**

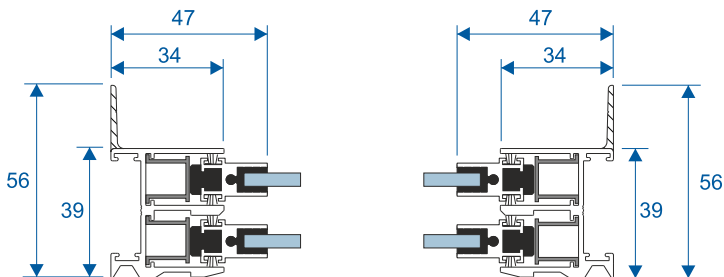

**Section C**

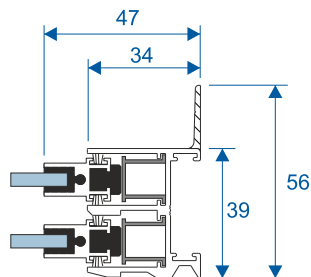

**Section D**

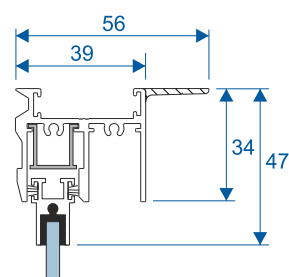

**Section E**

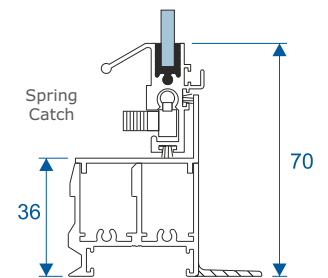

For more in-depth technical please contact us or consult our website.

# Hinged Units

## Friction Hinges

Single pane top hung or side hung (left or right) units are manufactured with Stainless Steel Friction Hinges to hold the casement to the desired position and fitted with a white painted Fitch Catch.

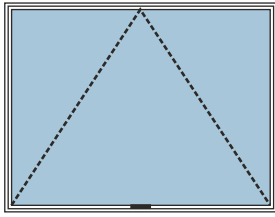

Top Hung (Friction Hinges)

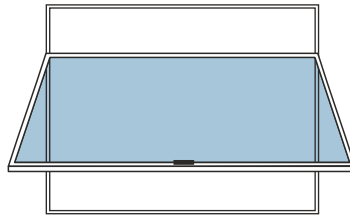

To Approx 65°

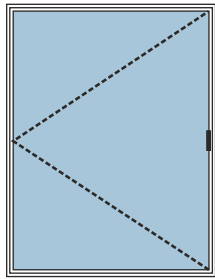

Side Hung (Friction Hinges)

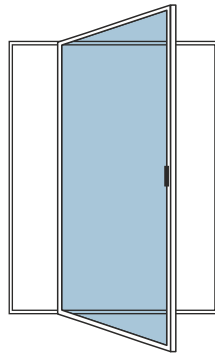

To Approx 65°

### Top Hung Recommended Sizes

|            |         |
|------------|---------|
| Min Width  | 350 mm  |
| Max Width  | 1250 mm |
| Min Height | 400 mm  |
| Max Height | 1000 mm |

### Side Hung Recommended Sizes

|            |         |
|------------|---------|
| Min Width  | 300 mm  |
| Max Width  | 650 mm  |
| Min Height | 400 mm  |
| Max Height | 1250 mm |

Please note that all these sizes are recommended sizes and special requests to go under or over these sizes may be possible but will not carry the standard guarantee.

## Friction Hinges - Economy Sections

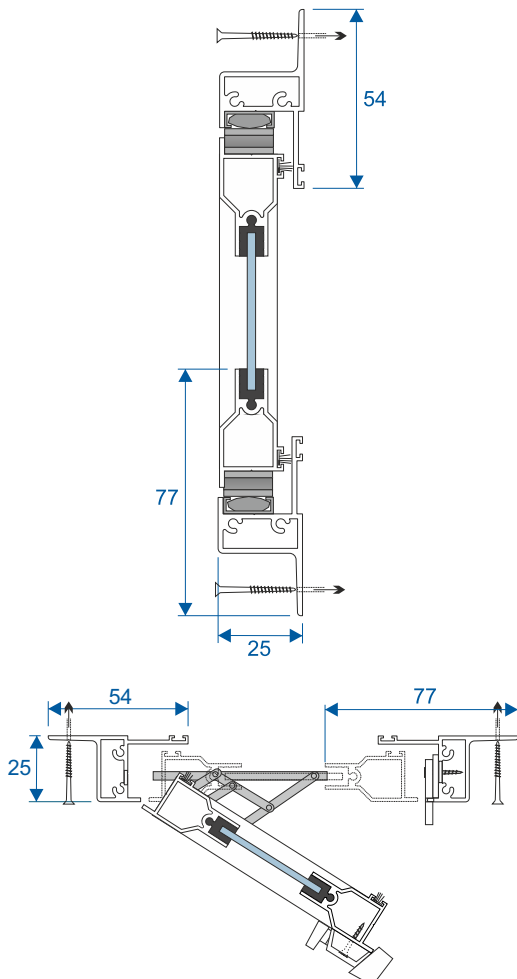

## Friction Hinges - Subframe Sections

Note drawings below show both face fix and reveal fix. Reveal fix shown by the hatched area.

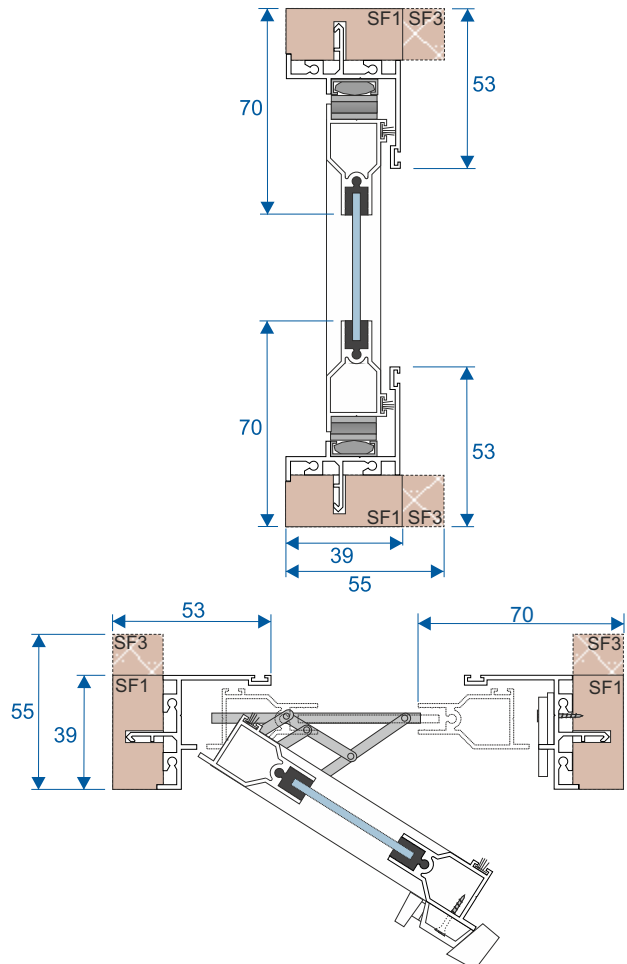

# Hinged Units

## Butt Hinges

Butt Hinged Units are manufactured as side hung and can be either single or double hinged as shown below. Heavy duty butt hinges are fitted to the casement enabling far greater access.

The single pane unit is fitted with a white painted Fitch Catch whilst the double unit is fitted with one or more Fitch Catches and has two concealed shoot bolts on the slave panel to secure it in a closed position.

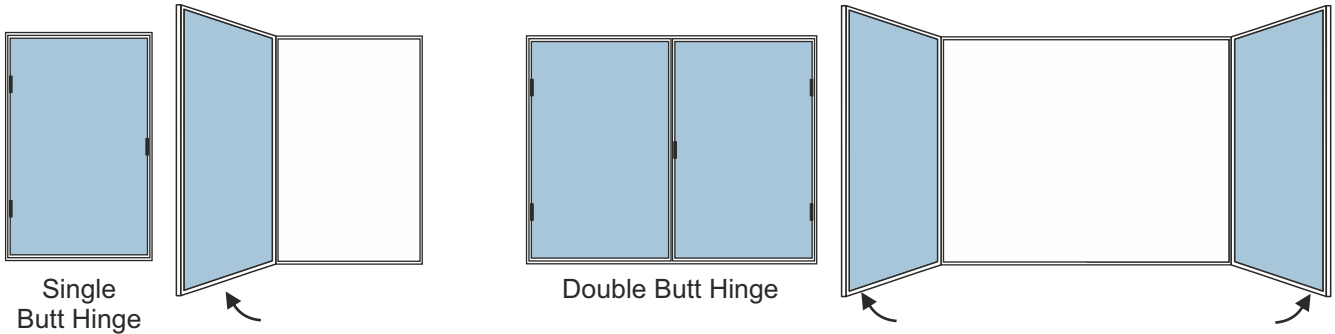

| Recommended Sizes Single Butt |         |
|-------------------------------|---------|
| Min Width                     | 300 mm  |
| Max Width                     | 900 mm  |
| Min Height                    | 400 mm  |
| Max Height                    | 2100 mm |

| Recommended Sizes Double Butt |         |
|-------------------------------|---------|
| Min Width                     | 700 mm  |
| Max Width                     | 1800 mm |
| Min Height                    | 400 mm  |
| Max Height                    | 2100 mm |

| Approximate Opening |      |
|---------------------|------|
| Economy             | 170° |
| Subframe            | 150° |

Please note that all these sizes are recommended sizes and special requests to go under or over these sizes may be possible but will not carry the standard guarantee.

### Butt Hinges - Economy Sections

### Butt Hinges - Subframe Sections

Note drawings below show both face fix and reveal fix. Reveal fix shown by the hatched area.

Single Butt

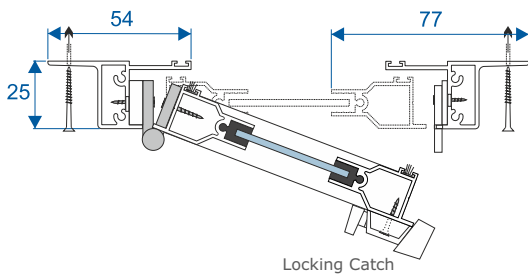

Single Butt

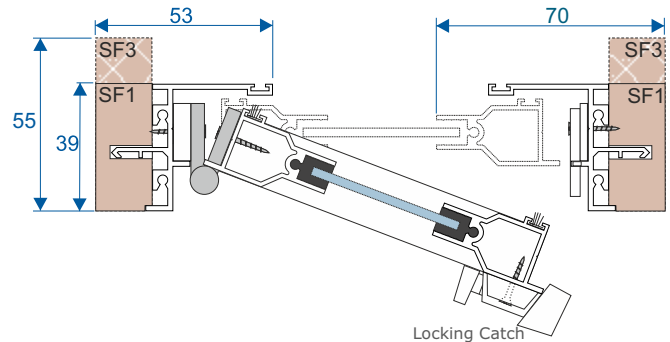

Double Butt

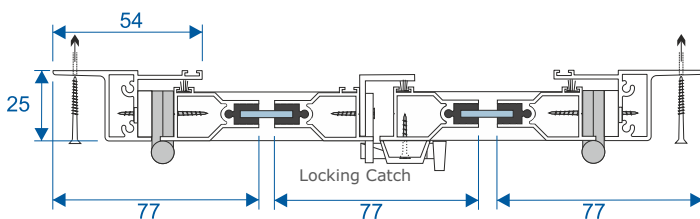

Double Butt

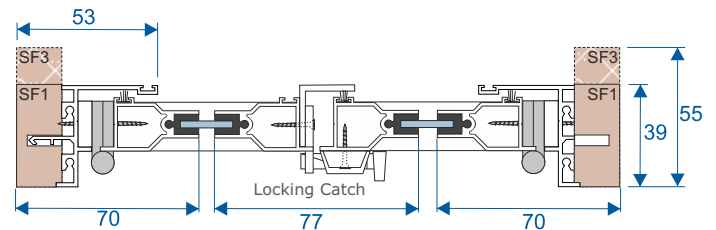

# Hinged & Combination Units

## Medium Duty Hinged Unit (Panel Only, No Frame)

These units consist of the PANEL ONLY i.e. no frame - and are supplied with medium duty plastic butt hinges and magnetic catch.

| Recommended Sizes |           |          |
|-------------------|-----------|----------|
|                   | Side Hung | Top Hung |
| Min Width         | 300 mm    | 300 mm   |
| Max Width         | 900 mm    | 1250 mm  |
| Min Height        | 400 mm    | 400 mm   |
| Max Height        | 1250 mm   | 1250 mm  |

Please note that all these sizes are recommended sizes and special requests to go under or over these sizes may be possible but will not carry the standard guarantee. Also note that it is not always recommended to use the max size on both width and height.

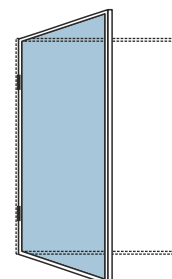
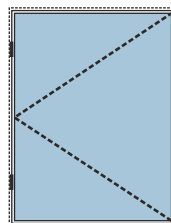
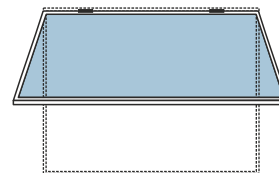
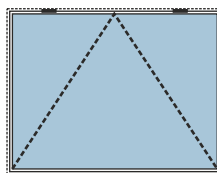

## Combination Units

Units are supplied with one outer frame divided by a transom / mullion.

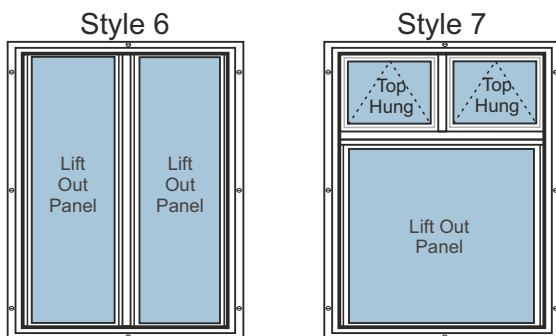
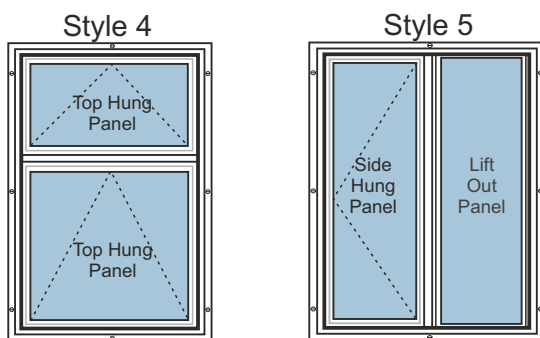
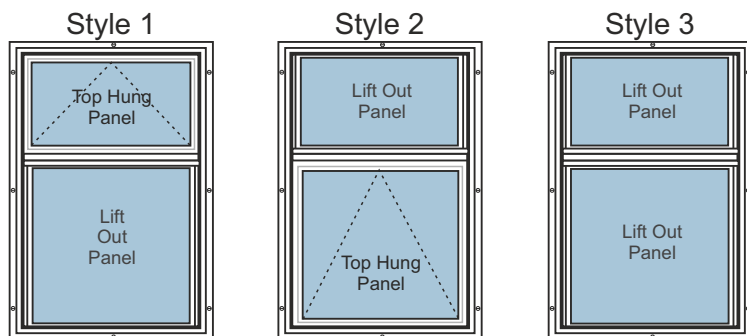

### Recommended Max Sizes

#### Top Hung / Lift Out (Style 1)

|            |         |
|------------|---------|
| Max Width  | 1200 mm |
| Max Height | 2600 mm |

#### Lift Out / Top Hung (Style 2)

|            |         |
|------------|---------|
| Max Width  | 1200 mm |
| Max Height | 2600 mm |

#### Lift Out / Lift Out (Style 3)

|            |         |
|------------|---------|
| Max Width  | 1200 mm |
| Max Height | 3000 mm |

#### Top Hung / Top Hung (Style 4)

|            |         |
|------------|---------|
| Max Width  | 1200 mm |
| Max Height | 2000 mm |

#### Side Hung / Lift Out (Style 5)

|            |         |
|------------|---------|
| Max Width  | 1800 mm |
| Max Height | 1500 mm |

#### Lift Out / Lift Out (Style 6)

|            |         |
|------------|---------|
| Max Width  | 2400 mm |
| Max Height | 1600 mm |

#### 2x Top Hung / Lift Out (Style 7)

|            |         |
|------------|---------|
| Max Width  | 1600 mm |
| Max Height | 2200 mm |

# Lift Outs

## Lift Out Units

Lift Out Units are framed single pane windows with a removable panel for cleaning: They are not suitable for ventilation. The removable panel has a full length finger rail at the bottom to assist in lifting the panel out. Panels over 1400mm in height are fitted with retaining clips to prevent the panel from bowing.

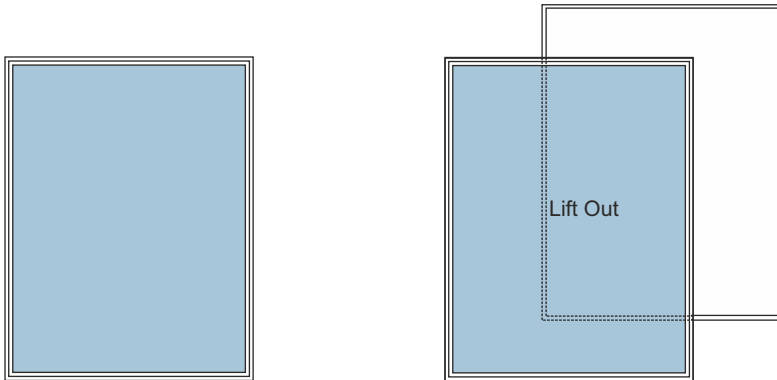

### Lift Out Recommended Sizes

|           |        |            |        |
|-----------|--------|------------|--------|
| Min Width | 300 mm | Min Height | 300 mm |
| Max Width | 1250mm | Max Height | 2100mm |

Please note that all these sizes are recommended sizes and special requests to go under or over these sizes may be possible but will not carry the standard guarantee.

Note drawings below show both face fix and reveal fix. Reveal fix shown by the hatched area.

### Economy Lift Out Sections

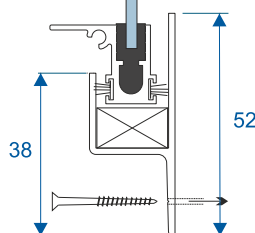
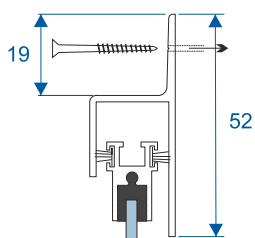
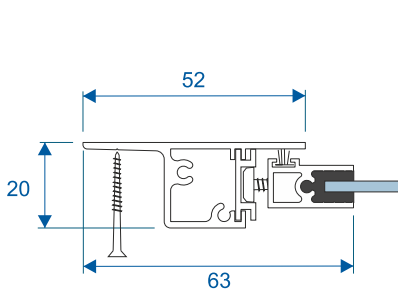

### Subframe Lift Out Sections

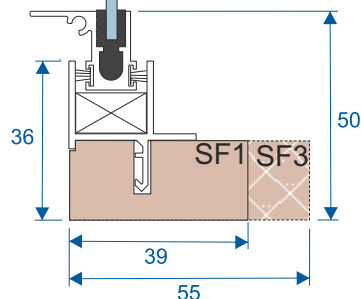
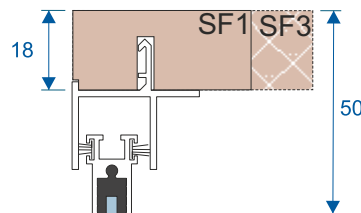
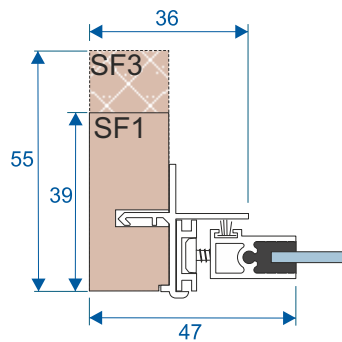

### Slim-Line Lift Out Sections

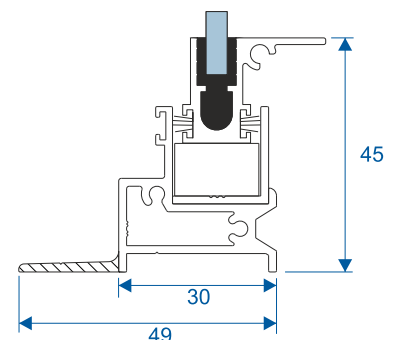
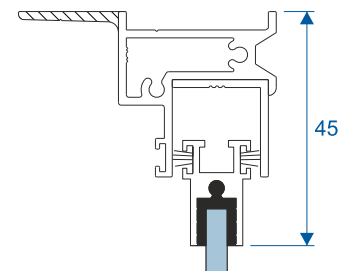
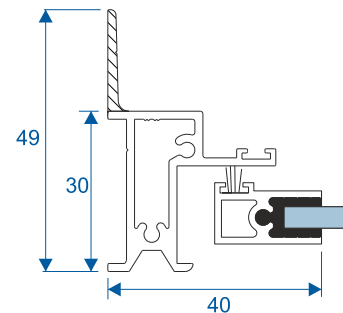

For more in-depth technical please contact us or consult our website.



# Fixed

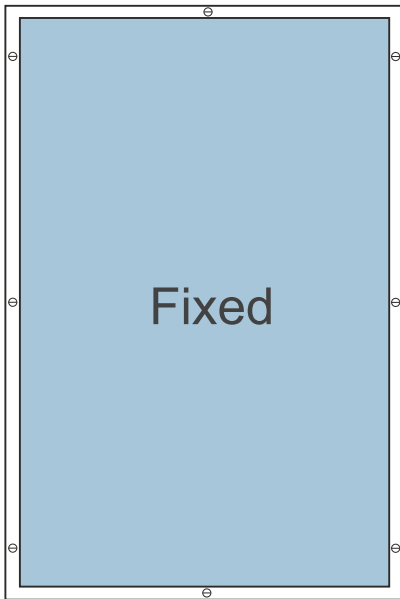

Fixed secondary glazing units are manufactured as a single pane glazed panel which fix directly to existing windows or doors with screws.

They have no opening mechanism and can not be easily removed for general cleaning or for ventilation.

The frames have pre-drilled fixing holes, prepped and countersunk ready for fixing.

## Fixed Recommended Sizes

|           |         |            |         |
|-----------|---------|------------|---------|
| Min Width | 300 mm  | Min Height | 300 mm  |
| Max Width | 1500 mm | Max Height | 2500 mm |

Please note that all these sizes are recommended sizes and special requests to go under or over these sizes may be possible but will not carry the standard guarantee.

## Sections

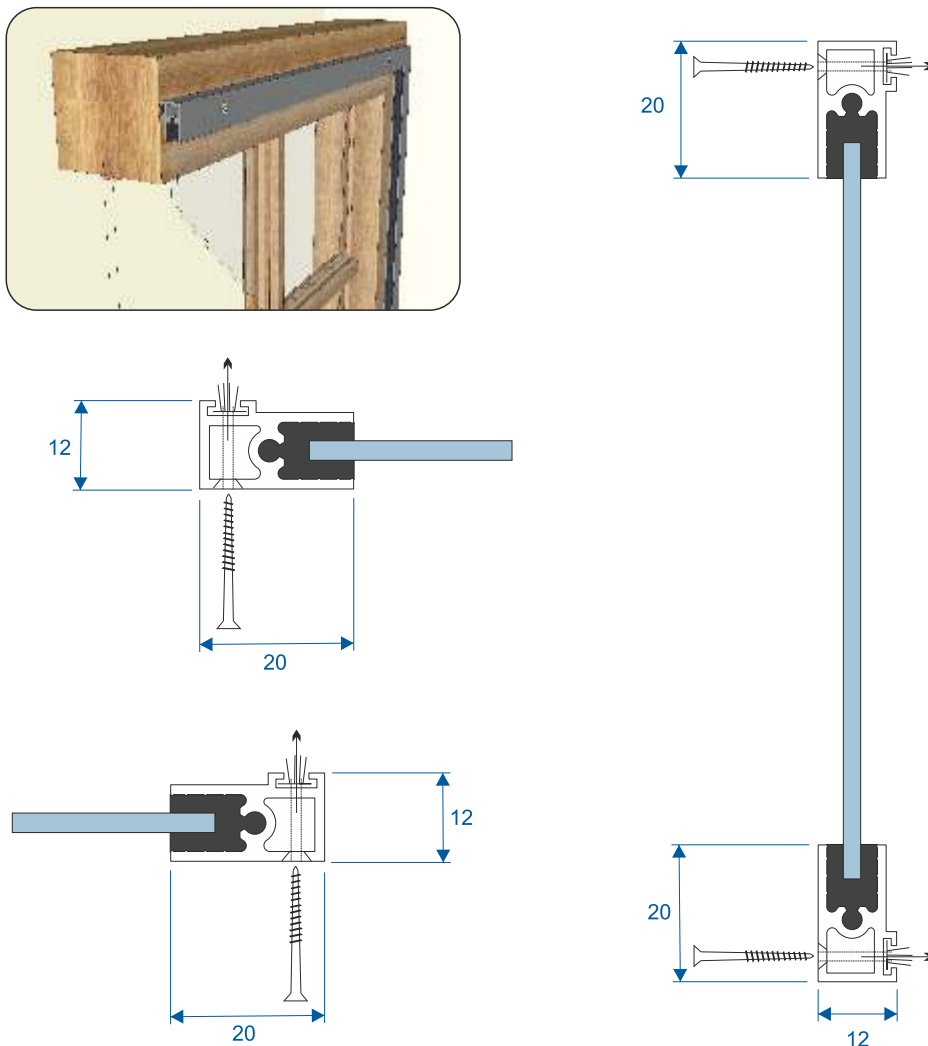

For more in-depth technical please contact us or consult our website.

# Fly Screens

## Fly Screen Windows

Manufactured from the same high quality materials as the glazed units these fine meshed panels allow windows to be opened without the fear of being invaded by flying insects.

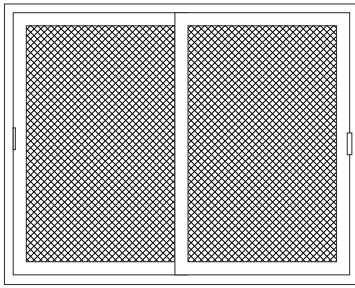

Horizontal Slider

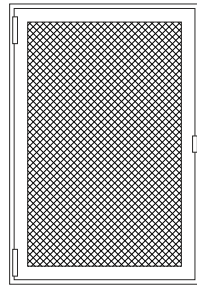

Hinged (with Subframe)

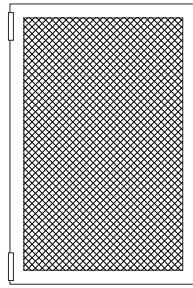

Hinged Panel (no Subframe)

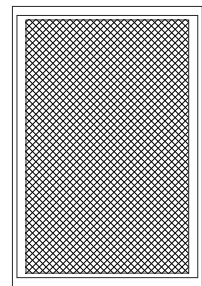

Lift Out

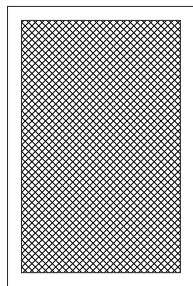

Fixed Panel (No Subframe)

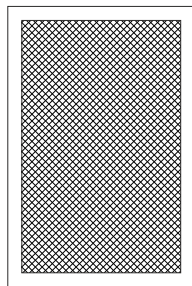

Insert Panel (in place of Glazed Panel)

### Recommended Max Sizes

#### Horizontal Slider

|            |         |
|------------|---------|
| Max Width  | 1300 mm |
| Max Height | 1200 mm |

#### Hinged (With Frame)

|            |         |
|------------|---------|
| Max Width  | 650 mm  |
| Max Height | 1200 mm |

#### Hinged Panel (No Frame)

|            |         |
|------------|---------|
| Max Width  | 650 mm  |
| Max Height | 1200 mm |

#### Fixed Panel

|            |         |
|------------|---------|
| Max Width  | 650 mm  |
| Max Height | 1200 mm |

#### Lift Out

|            |         |
|------------|---------|
| Max Width  | 650 mm  |
| Max Height | 1200 mm |

#### Insert Panel (In Place Of Glazed Panel)

|            |         |
|------------|---------|
| Max Width  | 650 mm  |
| Max Height | 1200 mm |

## Fly Screen Doors

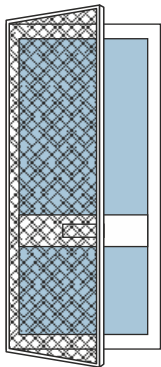

Section through Flyscreen Door showing typical installation inside the reveals

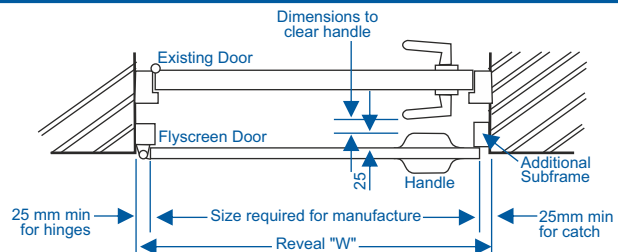

### Features of Our Flyscreen Doors

- Maintenance Free Aluminium.
- Strong Nylon coated fibre glass mesh.
- Choice of White, Silver or Brown Finish.
- To Fit Doors up to 900mm x 2150mm.
- Inward or Outward opening.
- Will lift off for Easy Storage.

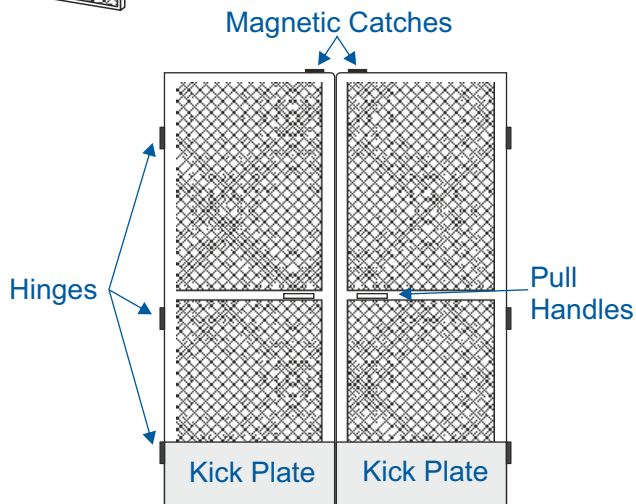

Meeting stile angle 7/8" x 7/8" x 1/16" on the slave door  
Fitted on site in position required

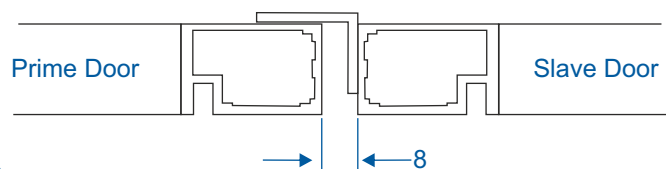

Note: Maximum handle clearance is 40mm from the inside face of the frame

# Trickle Vents & Trims

## Trickle Vents

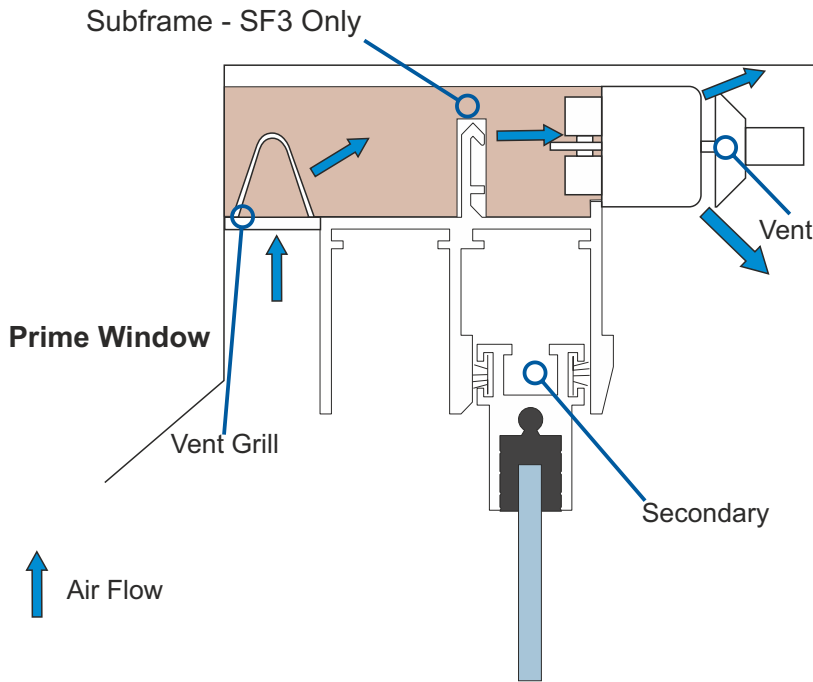

Trickle vents can only be used with a SF3 reveal fix subframe.

The vent is placed within the subframe and provides additional ventilation.

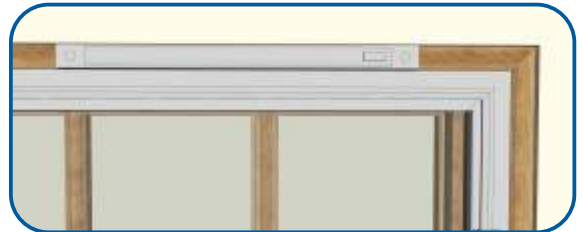

## Trims

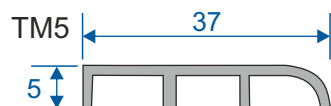
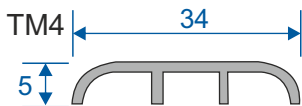
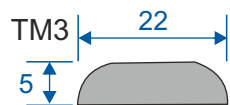
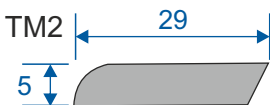
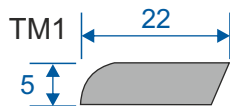
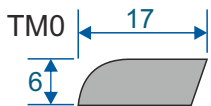

Economy odd leg, heavy duty & fixed are not provided with trims. Luxury Subframe is provided with TM1 white plastic as standard. Slim Line Equal leg is provided with TM0 primed tulip as standard.

Both luxury subframe and slim line equal leg can be provide with a different trim if requested at the point of order.

Trim material options:

- TM0 - Tulip, Primed Tulip or Solid Oak.
- TM1 - White Plastic, Tulip, Primed Tulip or Solid Oak.
- TM2 - White Plastic, Tulip, Primed Tulip or Solid Oak.
- TM3 - White Plastic, Tulip, Primed Tulip or Solid Oak.
- TM4 - White Plastic, Tulip, Primed Tulip or Solid Oak.
- TM5 - White Plastic, Tulip, Primed Tulip or Solid Oak.

We reserves the right to make changes to product specification. The images used are artistic representations and are not binding in detail, colour or specification.

Duration Windows  
Thames Development  
Charfleets Road  
Canvey Island  
Essex. SS8 0PQ

[sales@duration.co.uk](mailto:sales@duration.co.uk)  
[www.duration.co.uk](http://www.duration.co.uk)

**Head Office** 01268 681612  
**Showroom** 01268 695100